

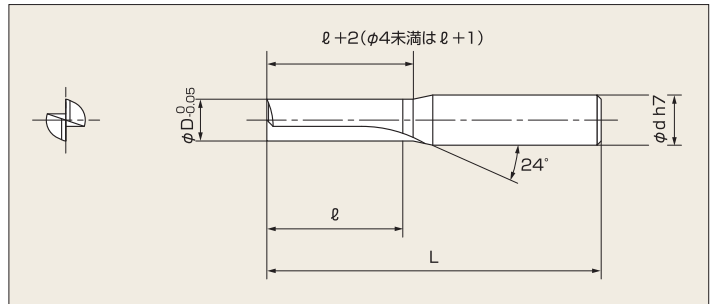

ソリッドスロッチングロングエンドミル S-LSLE

SOLID CARBIDE STRAIGHT LONG 2 FLUTE END MILL



外径 (φD)	刃長 (ℓ)	全長 (L)	シャンク径 (φd)
2.0	15	60	4
2.5			
3.0			
3.5			
4.0	25	70	6
4.5			
5.0			
5.5			
6.0			
6.5			
7.0			
7.5	30	80	8
8.0			
8.5			
9.0			
9.5			
10.0			
10.5	35	90	10
11.0			
11.5			
12.0			
12.5			
13.0	40	16	12
13.5			
14.0			
14.5			
14.5			

外径 (φD)	刃長 (ℓ)	全長 (L)	シャンク径 (φd)
15.0	45	100	16
15.5			
16.0			
16.5			
17.0			
17.5			
18.0	50	110	20
18.5			
19.0			
19.5			
20.0			
20.0			