

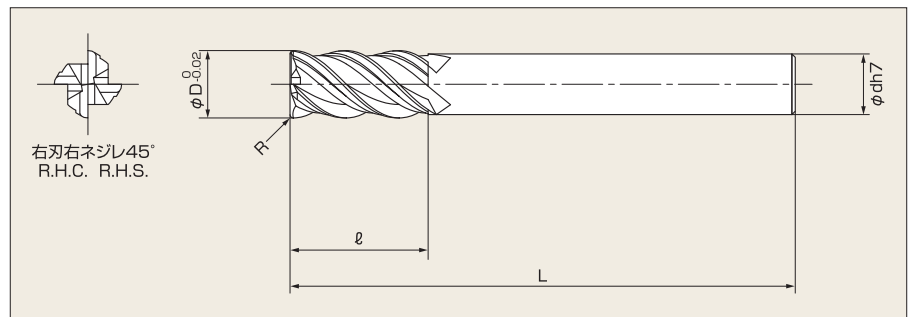

Cロング4枚刃Rスレンダー TIALNコート C-RLSS4

SOLID CARBIDE SLENDER SHANK LONG IN NECK 4 FLUTE END MILL WITH CORNER RADIUS (TIALN)



外径 (φD)	コーナー (R)	刃長 (ℓ)	全長 (L)	シャンク径 (φd)
4	0.2	10	90	3
	0.3			
	0.5			
	1.0			
6	0.2	15	105	6
	0.3			
	0.5			
	1.0			
	1.5			
8	0.5	20	120	8
	1.0			
	1.5			
	2.0			
10	0.5	30	150	14
	1.0			
	1.5			
	2.0			
	3.0			

外径 (φD)	コーナー (R)	刃長 (ℓ)	全長 (L)	シャンク径 (φd)
12	0.5	25	135	10
	1.0			
	1.5			
	2.0			
	3.0			
16	0.5	40	150	18
	1.0			
	2.0			
	3.0			
	4.0			
	5.0			
20	0.5	40	150	18
	1.0			
	2.0			
	3.0			