

SSS Tスロットカッター TC

K20 CARBIDE TIPPED T SLOT CUTTER WITH SHANK

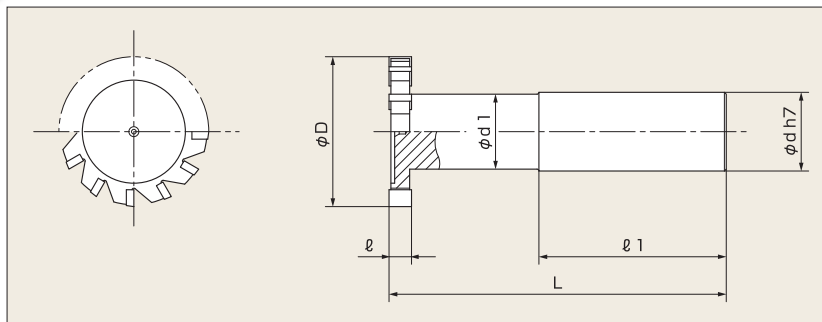
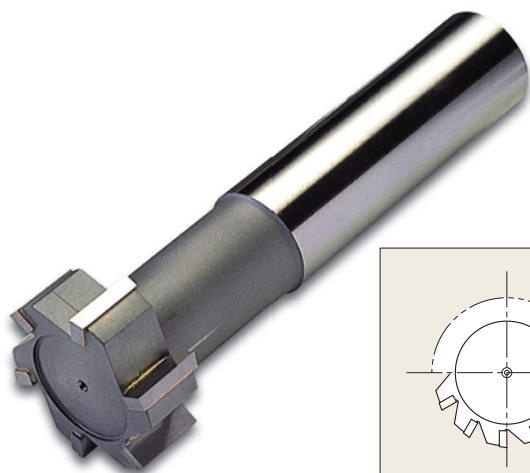

外径 (φD)	外径 許容差	刃幅 (ℓ)	刃幅 許容差	首径 (φd1)	全長 (L)	シャンク径 (φd)	シャンク長 (ℓ1)	刃数 (N)
15		3		6	80		12	4
		4	-0.030					
		5	-0.105					
		6						
		7						
		8	-0.040					
		9	-0.130					
		10						
		11	-0.050					
		12	-0.160					
16	-0.050 -0.160	3		7	16		16	6
		4	-0.030					
		5	-0.105					
		6						
		7						
		8	-0.040					
		9	-0.130					
		10						
		11	-0.050					
		12	-0.160					
18		3		7	16		16	6
		4	-0.030					
		5	-0.105					
		6						
		7						
		8	-0.040					
		9	-0.130					
		10						
		11	-0.050					
		12	-0.160					

外径 (φD)	外径 許容差	刃幅 (ℓ)	刃幅 許容差	首径 (φd1)	全長 (L)	シャンク径 (φd)	シャンク長 (ℓ1)	刃数 (N)							
20		3		9	95		16	6							
		4	-0.030												
		5	-0.105												
		6													
		7													
		8	-0.040												
		9	-0.130												
		10													
		11	-0.050												
		12	-0.160												
		22	-0.065 -0.195						3		11	20		20	6
									4	-0.030					
5	-0.105														
6															
7															
8	-0.040														
9	-0.130														
10															
11	-0.050														
12	-0.160														



Tスロットカッター TC

CARBIDE TIPPED T SLOT CUTTER WITH SHANK

外径 (φD)	外径 許容差	刃幅 (φ)	刃幅 許容差	首径 (φd1)	全長 (L)	シャン径 (φd)	シャン長 (φ1)	刃数 (N)							
24	-0.065 -0.195	3		12	100	20	70	6							
		4	-0.030												
		5	-0.105												
		6													
		7													
		8	-0.040												
		9	-0.130												
		10													
		11													
		12													
		13	-0.050												
		14	-0.160												
		15													
		25	-0.065 -0.195						3		12	100	20	70	6
									4	-0.030					
5	-0.105														
6															
7															
8	-0.040														
9	-0.130														
10															
11															
12															
13	-0.050														
14	-0.160														
15															
28	-0.065 -0.195			3		15	100	20	70	6					
				4	-0.030										
		5	-0.105												
		6													
		7													
		8	-0.040												
		9	-0.130												
		10													
		11													
		12													
		13	-0.050												
		14	-0.160												
		15													

外径 (φD)	外径 許容差	刃幅 (φ)	刃幅 許容差	首径 (φd1)	全長 (L)	シャン径 (φd)	シャン長 (φ1)	刃数 (N)
30	-0.065 -0.195	3		17	110	25	75	6
		4	-0.030					
		5	-0.105					
		6						
		7						
		8	-0.040					
		9	-0.130					
		10						
		11						
		12						
		13	-0.050					
		14	-0.160					
		15						
		16						
		32	-0.065 -0.195					
4	-0.030							
5	-0.105							
6								
7								
8	-0.040							
9	-0.130							
10								
11								
12								
13								
14	-0.050							
15	-0.160							
16								
17								
18								
19	-0.065							
20	-0.195							



Tスロットカッター TC

CARBIDE TIPPED T SLOT CUTTER WITH SHANK

外径 (φD)	外径 許容差	刃幅 (φ)	刃幅 許容差	首径 (φd1)	全長 (L)	シャン径 (φd)	シャン長 (φl)	刃数 (N)
35	-0.080 -0.240	3		20	115	25	80	6
		4	-0.030					
		5	-0.105					
		6						
		7						
		8	-0.040					
		9	-0.130					
		10						
		11						
		12						
		13						
		14	-0.050					
		15	-0.160					
		16						
		17						
		18						
		19	-0.065					
		20	-0.195					
38	-0.080 -0.240	3		23	115	25	80	6
		4	-0.030					
		5	-0.105					
		6						
		7						
		8	-0.040					
		9	-0.130					
		10						
		11						
		12						
		13						
		14	-0.050					
15	-0.160							
16								
17								
18								
19	-0.065							
20	-0.195							

外径 (φD)	外径 許容差	刃幅 (φ)	刃幅 許容差	首径 (φd1)	全長 (L)	シャン径 (φd)	シャン長 (φl)	刃数 (N)
40	-0.080 -0.240	3		23	130	25	80	6
		4	-0.030					
		5	-0.105					
		6						
		7						
		8	-0.040					
		9	-0.130					
		10						
		11						
		12						
		13						
		14	-0.050					
		15	-0.160					
		16						
		17						
		18						
		19	-0.065					
		20	-0.195					
45	-0.080 -0.240	3		23	135	25	80	6
		4	-0.030					
		5	-0.105					
		6						
		7						
		8	-0.040					
		9	-0.130					
		10						
		11						
		12						
		13						
		14	-0.050					
15	-0.160							
16								
17								
18								
19	-0.065							
20	-0.195							



Tスロットカッター TC

CARBIDE TIPPED T SLOT CUTTER WITH SHANK

外径 (φD)	外径 許容差	刃幅 (φ)	刃幅 許容差	首径 (φd1)	全長 (L)	シャン径 (φd)	シャン長 (φl)	刃数 (N)						
50	-0.080 -0.240	3		30	150	32	100	8						
		4	-0.030											
		5	-0.105											
		6												
		7												
		8	-0.040											
		9	-0.130											
		10												
		11												
		12												
		13												
		14	-0.050											
		15	-0.160											
		16												
		17												
		18												
		19	-0.065											
		20	-0.195											
		55	-0.100 -0.290		3				-0.020 -0.080	30	150	32	100	8
					4				-0.030					
5	-0.105													
6														
7														
8	-0.040													
9	-0.130													
10														
11														
12														
13														
14	-0.050													
15	-0.160													
16														
17														
18														
19	-0.065													
20	-0.195													
60	-0.100 -0.290			3	-0.020 -0.080	30	165	32	100		8			
				4	-0.030									
		5	-0.105											
		6												
		7												
		8	-0.040											
		9	-0.130											
		10												
		11												
		12												
		13												
		14	-0.050											
		15	-0.160											
		16												
		17												
		18												
		19	-0.065											
		20	-0.195											
		65	-0.100 -0.290	3	-0.020 -0.080		30			175		32	100	8
				4	-0.030									
5	-0.105													
6														
7														
8	-0.040													
9	-0.130													
10														
11														
12														
13														
14	-0.050													
15	-0.160													
16														
17														
18														
19	-0.065													
20	-0.195													
21	-0.065													
22	-0.195													
23														
24														
25														

外径 (φD)	外径 許容差	刃幅 (φ)	刃幅 許容差	首径 (φd1)	全長 (L)	シャン径 (φd)	シャン長 (φl)	刃数 (N)						
50	-0.080 -0.240	3	-0.020 -0.080	30	150	32	100	8						
		4	-0.030											
		5	-0.105											
		6												
		7												
		8	-0.040											
		9	-0.130											
		10												
		11												
		12												
		13												
		14	-0.050											
		15	-0.160											
		16												
		17												
		18												
		19	-0.065											
		20	-0.195											
		55	-0.100 -0.290		3				-0.020 -0.080	30	150	32	100	8
					4				-0.030					
5	-0.105													
6														
7														
8	-0.040													
9	-0.130													
10														
11														
12														
13														
14	-0.050													
15	-0.160													
16														
17														
18														
19	-0.065													
20	-0.195													
60	-0.100 -0.290			3	-0.020 -0.080	30	165	32	100		8			
				4	-0.030									
		5	-0.105											
		6												
		7												
		8	-0.040											
		9	-0.130											
		10												
		11												
		12												
		13												
		14	-0.050											
		15	-0.160											
		16												
		17												
		18												
		19	-0.065											
		20	-0.195											
		65	-0.100 -0.290	3	-0.020 -0.080		30			175		32	100	8
				4	-0.030									
5	-0.105													
6														
7														
8	-0.040													
9	-0.130													
10														
11														
12														
13														
14	-0.050													
15	-0.160													
16														
17														
18														
19	-0.065													
20	-0.195													
21	-0.065													
22	-0.195													
23														
24														
25														



Tスロットカッター TC

CARBIDE TIPPED T SLOT CUTTER WITH SHANK

外径 (φD)	外径 許容差	刃幅 (φ)	刃幅 許容差	首径 (φd1)	全長 (L)	シャンク径 (φd)	シャンク長 (φl)	刃数 (N)						
80	-0.100 -0.290	5	-0.030	40	180	42	100	12						
		6	-0.105											
		7												
		8	-0.040											
		9	-0.130											
		10												
		11												
		12												
		13												
		14	-0.050											
		15	-0.160											
		16												
		17												
		18												
		19	-0.065											
		20	-0.195											
		90	-0.120 -0.340		5				-0.030	40	190	42	100	12
					6				-0.105					
					7									
					8				-0.040					
9	-0.130													
10														
11														
12														
13														
14	-0.050													
15	-0.160													
16														
17														
18														
19	-0.065													
20	-0.195													
							200							

外径 (φD)	外径 許容差	刃幅 (φ)	刃幅 許容差	首径 (φd1)	全長 (L)	シャンク径 (φd)	シャンク長 (φl)	刃数 (N)						
100	-0.120 -0.340	5	-0.030	40	190	42	100	12						
		6	-0.105											
		7												
		8	-0.040											
		9	-0.130											
		10												
		11												
		12												
		13												
		14	-0.050											
		15	-0.160											
		16												
		17												
		18												
		19	-0.065											
		20	-0.195											
											200			