

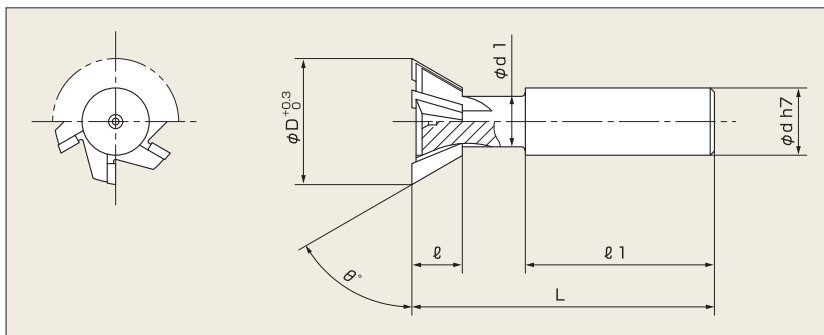

柄付アンギュラーカッター(シングル) AGC

CARBIDE TIPPED SHIGLE ANGULAR CUTTER WITH SHANK



■シングル45°

呼称 (φD×θ°)	外径 (φD)	刃長 (ℓ)	首径 (φd1)	全長 (L)	シャンク径 (φd)	シャンク長 (ℓ1)	刃数 (N)
20×S45°	20	5	8.5	70	16	45	6
25×S45°	25	6	10				
30×S45°	30	8	11				
35×S45°	35	10	12	80	50		
40×S45°	40		14	90	20		
45×S45°	45	12	18	95	25	55	
50×S45°	50	15	20	100			
60×S45°	60	18	22	110	32	60	8
65×S45°	65		24	120			
70×S45°	70	20	24	130	70		
75×S45°	75	22	25				
80×S45°	80	25					

■シングル60°

呼称 (φD×θ°)	外径 (φD)	刃長 (ℓ)	首径 (φd1)	全長 (L)	シャンク径 (φd)	シャンク長 (ℓ1)	刃数 (N)
15×S60°	15	5	6	60	12	40	4
20×S60°	20	8	9	68	16	43	
25×S60°	25	12	9.5	72		45	
30×S60°	30	15	14	85	20	50	6
35×S60°	35		19	93		55	
40×S60°	40	20	20	95	25	55	
45×S60°	45	25	22	100			
50×S60°	50	30	23	109	32	57	8
55×S60°	55		24	115		60	
60×S60°	60	35	28	135	70		
65×S60°	65	42	30	157		80	10
70×S60°	70						
75×S60°	75						
80×S60°	80						
90×S60°	90						
100×S60°	100						